

Shutter Installation Instructions Deco Frame or L Frame Outside Mount 2 Sides Cafe Shutters

CONGRATULATIONS on purchasing the finest shutters in the market.

You can take pride that your purchase will enhance the function and beauty of your home.

INSTALLATION OVERVIEW

Getting Started

- Step 1: Assemble Frame
- Step 2: Attach the Panels
- Step 3: Secure the Light Block
- Step 4: Add the Finishing Touch



Installation Video

Scan the QR code with your smartphone to follow along with video instructions.



IMPORTANT: Do not mix panels or frames from other windows. Install one shutter at a time.

Tools needed for installing your shutter:

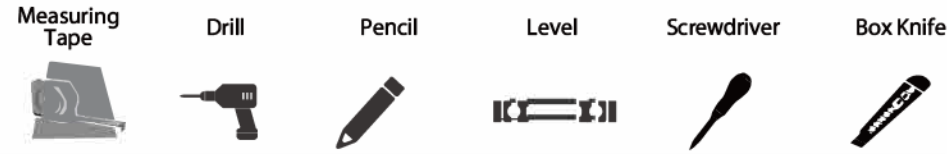

Getting Started

Remove the shutter from the package. Do not discard any of the packaging material until the shutter operates to your satisfaction. Check the diagram below to make sure you have the necessary parts.

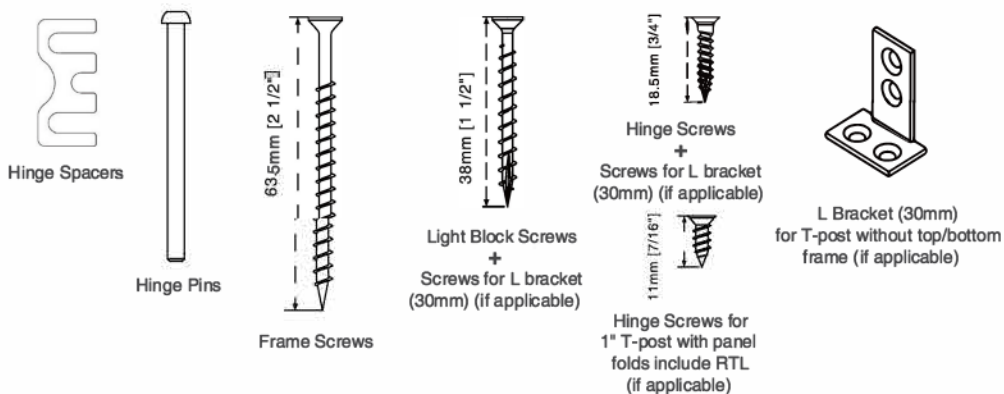
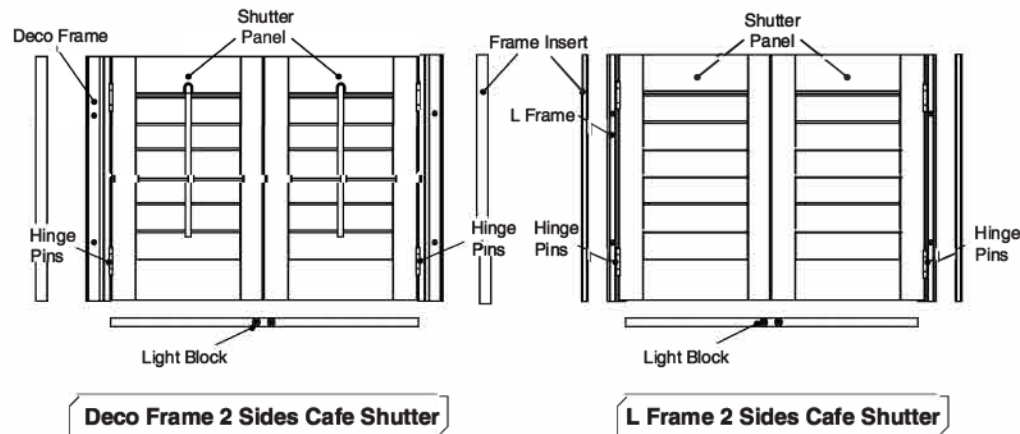

Step 1: Assemble Frame

- Carefully remove panels and frames from the packaging. Do not mix panels or frames from other windows. Frame pieces are labeled: left and right. To separate the frame inserts from the frames, gently lift the frame insert from one side of the frame. Then carefully slide the insert out of the frame.

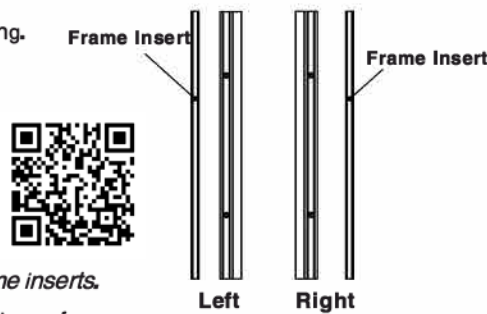

Scan the QR code to watch how to remove the frame inserts.

- On a soft, level surface (moving blankets or some type of pad works best) place the left and right frames opposite each other the approximate width of the window opening.

- If installing with T-post, use L bracket(30mm) to secure the T-post. Fasten the T-post with additional nails if necessary. If not installing with T-post, skip to the next step.

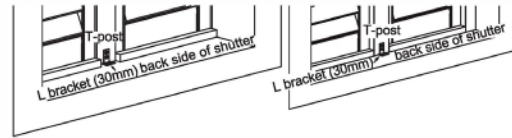

Step 2: Attach the Panels

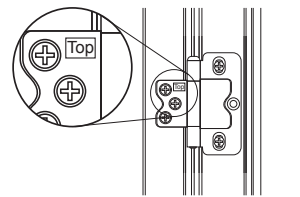

⚠ To ensure panels are installed correctly: Identify the top and bottom of the panel by locating the top label on the top hinge.

Single panel or hinged on 1 side only

- Align the panel with the hinged side of the frame. Secure the hinges with supplied hinge pins.

If you have bi-fold panels, start by securing this first panel to the frame. Then join the hinges of the panels labeled P1 and P2 and insert the hinge pins.

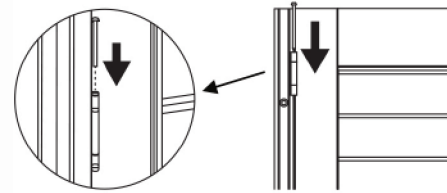

- Position the non-hinged frame against the shutter panel. There should be approximately 1/8" of space between the panel and frame from the top of the panel to the bottom.

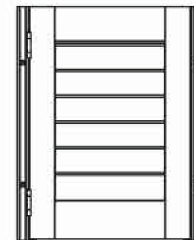

- With the frames and panel still lying on the floor, measure the distance from the outside edge of the left frame to the outside edge of the right frame. Record the distance.



- With the width measurement recorded in #3, center the tape measure on the window opening. With a pencil or painter's tape, mark the outside left and right frame measurements.



- Remove the hinge pins from the panel. Place the outside of the hinged frame against the recorded mark on the window opening. Using a level, ensure the frame is straight up and down. Temporarily secure the top and bottom of the frame with screws.

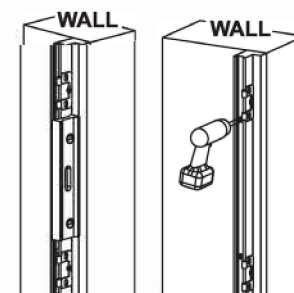

- Align the panel with the hinges of the installed frame and secure with hinge pins.

If you have bi-fold panels, start by securing this first panel to the frame. Then join the hinges of the panels labeled P1 and P2 and insert the hinge pins.

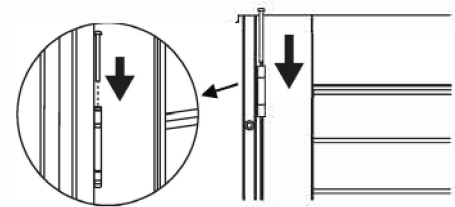

- Open & close panel and check for bottom clearance. Adjust hinges up or down as needed to gain or reduce bottom clearance.

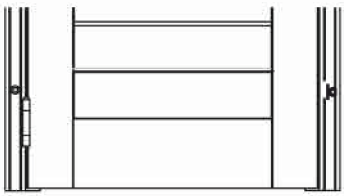

- Place remaining frame against mark recorded in #4. Temporarily secure with one screw.

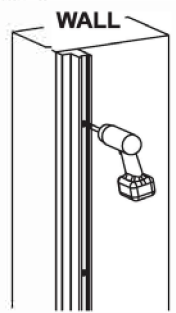

- Close the panel against the frame and check the spacing between the panel and the frame. Maintaining 1/8" of space, secure the bottom of the newly installed frame. Use shims as necessary.

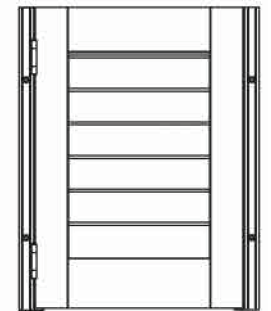

- Close the panel against the frame and check the spacing between the panel and the frame. Maintaining 1/8" of space, secure the bottom of the newly installed frame. Use shims as necessary. Once desired spacing has been achieved, secure frames with remaining screws.

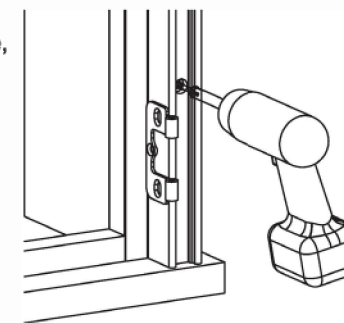

- Open & close panel and make any final adjustments. Use provided hinge spacers to adjust spacing if necessary.

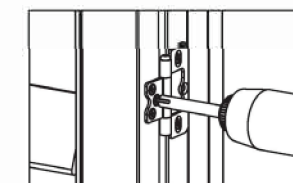

Loosen hinge screws on the panel

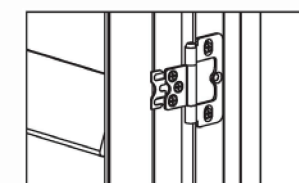

Insert spacer behind hinge, tighten screws



Spacer installed

- Fasten all the hinges by tightening the deadlock screw for each.

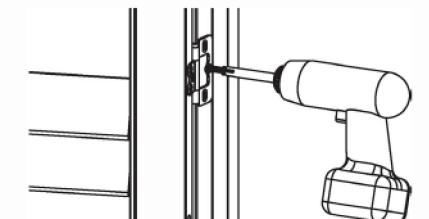
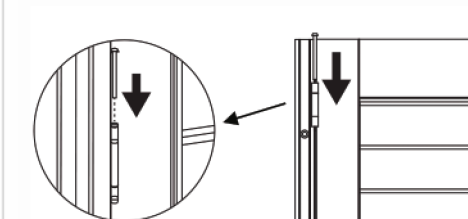

Multiple panels – hinged on both frames

1. Lay all panels into the both the left and right frame hinges and secure with hinge pins.

If you have bi-fold panels, after attaching the far left and/or far right panels to the frame, you will need to join the hinges of the panels labeled P1 and P2 and insert hinge pins. Repeat for panels labeled P3 and P4 if you have these. Proper order of panels from left to right is P1, P2, P3, P4.

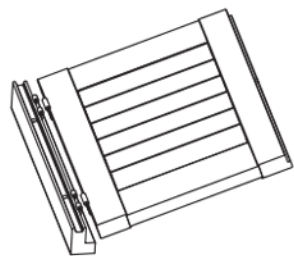

2. Close the left and right panel sections and check center spacing. Adjust frames by sliding them closer to or farther away from each other to achieve even spacing where the center panels come together. Make sure the panels/frames are level to each other by ensuring the panel tops and bottoms line up with each other.

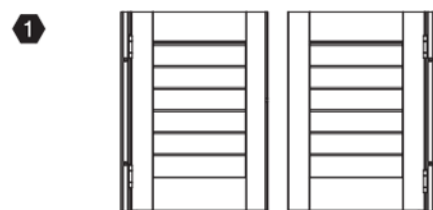

3. With the frames and panels still lying on the floor, measure the distance from the outside edge of the left frame to the outside edge of the right frame. Record the distance.



4. With the width measurement recorded in #3, center the tape measure on the window opening. With a pencil or painter's tape, mark the outside left and right frame measurements at the bottom and top heights of the frames.



5. Remove the hinge pins from the panels. Place the outside of the left frame against the recorded top & bottom marks on the window opening. Using a level, ensure the frame is straight up and down. Temporarily secure the top and bottom of the frame with screws.

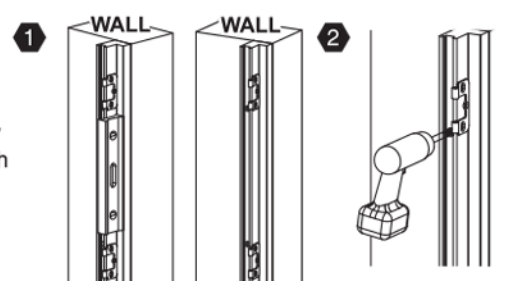

6. Repeat #5 for the right frame.

7. Align the panels with the hinges of the installed frames and secure with hinge pins.

If you have bi-fold panels, after attaching the far left and/or far right panels to the frame, you will need to join the hinges of the panels labeled P1 and P2 and insert hinge pins. Repeat for panels labeled P3 and P4 if you have these. Proper order of panels from left to right is P1, P2, P3, P4.

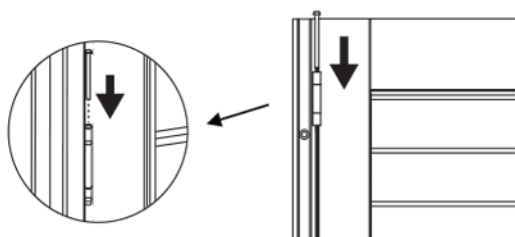

8. Close the panels against each other. Check the spacing between the panels, and ensure the panel tops line up.

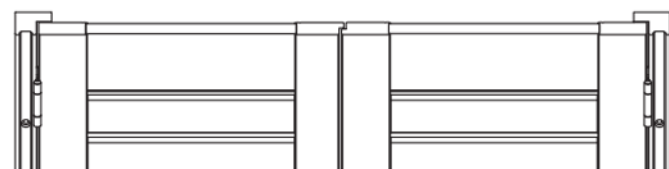

9. Once desired spacing has been achieved, secure frames with remaining screws.



10. Open & close panels and make any final adjustments. Use provided hinge spacers to adjust spacing if necessary. Panel heights can be adjusted by moving hinges up or down.

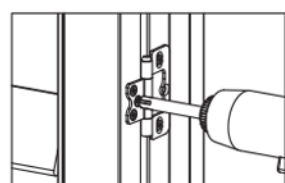

Loosen hinge screws on the panel

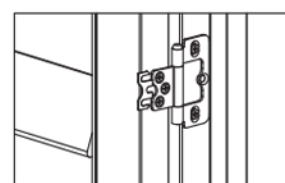

Insert spacer behind hinge, tighten screws

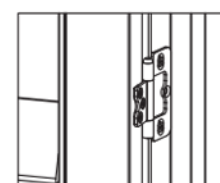

Spacer installed

11. Fasten all the hinges by tightening the deadlock screw for each.

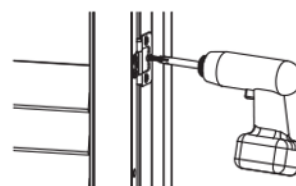

Step 3: Secure the Light Block

1. Open shutter panels and position the light block on the window sill. The front of the light block should be flush with the front of the left and right frames.
2. Once aligned properly, secure the light block with the light block screws provided through each pre-drilled hole.

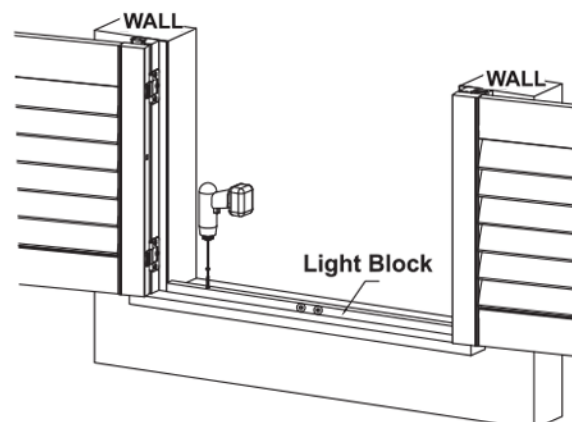

Step 4: Add the Finishing Touch

IMPORTANT: Check shutter operation and alignment before installing frame inserts, as frame inserts can NOT be removed once they are snapped into place.

Match each frame insert with the corresponding side of the frame: Left to Left, Right to Right.

Snap the frame inserts into place (OR remove double-sided foam tape and put the frame insert into place).

This will cover screws and provide a finished look.

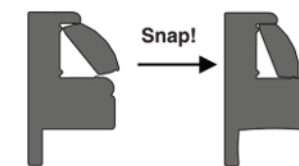

Snap!

Double-sided foam tape for wood frame only: Remove double-sided foam tape and put the frame insert into place.

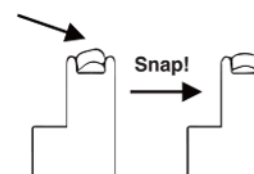
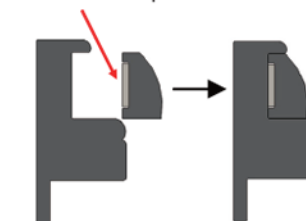

Snap!

Double-sided foam tape for wood frame only: remove double-sided foam tape and put the frame insert into place.

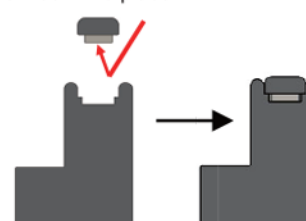

Maintain Your Shutter

Use a clean dry cloth, feather duster or vacuum with brush attachment to gently remove dust and debris. To ensure thorough cleaning, wipe the louvers in the open and closed positions. Do not immerse the product in water and do not use harsh chemicals to clean. This may cause discoloration and the wood to warp. Ultrasonic cleaning is not recommended. For best results on Composite Shutters, use a cotton cloth dampened with water. Polyester cloths tend to create static, which can attract dust.

Adjust the Tension System

If over a period of time the louvers on your shutters should loosen or not function properly, a built-in tension system can be adjusted. Simply open the panels fully and find the tension adjuster screw hole on the side of each panel. Use a screwdriver to gently turn the screw on each side of the panel to your desired resistance level. Repeat process for other panel(s) if necessary.

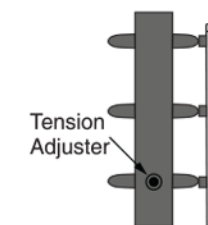

Lifetime Limited Warranty

All Acadia Living shutters have a lifetime limited warranty and will be free from defects in materials or workmanship for as long as the original retail purchaser owns the shutters, provided that such products were properly installed in residential dwelling; and such products were made or assembled exclusively from original materials and components. Any resale or other transfer of the product and/or materials voids this warranty.

For a complete copy of this warranty, please contact customer service by phone or email.

Customer Service

Phone: 855.667.6261

Email: Blinds.comSupport@NormanUSA.com